

(OPTIONAL VENT HOODS SHOWN)

V1 VENT CONNECTION—ENTRANCE END: 4" WIDE x 16" LONG (INSIDE DIM.) WITH LOCKING TYPE DAMPER. 200 C.F.M.

V2 VENT CONNECTION—DISCHARGE END: 4" WIDE x 16" LONG (INSIDE DIM.) WITH LOCKING TYPE DAMPER. 400 C.F.M.

SERVICE CONNECTION FOR MOTORS AND CONTROLS

MOTORS: 1/6 HP CONVEYOR  
2 HP WASH

VOLTAGE	RATED AMPS	MINIMUM SUPPLY CIRCUIT CONDUCTOR AMPACITY	MAXIMUM PROTECTIVE DEVICE
200-240/50/3	16.6	20	20
208-240/60/3	16.3	20	20
380-415/50/3	10.1	15	15
380/60/3	11.1	15	15
480/60/3	9.4	15	15
600/60/3	8.4	15	15
208-240/60/1	27.2	35	35

BOOSTER HEAT 30 KW

ELEC. SPECS.	RATED AMPS	MINIMUM SUPPLY CIRCUIT CONDUCTOR AMPACITY	MAXIMUM PROTECTIVE DEVICE
200-240/50/3	80.2	90	90
380-415/50/3	53.2	60	60
200/50/3	80.8	90	90
208-240/60/3	80.2	90	90
208/60/3	83.9	90	90
240/60/3	80.2	90	90
380/60/3	42.5	60	60
380-415/60/3	46.4	60	60
480/60/3	40.1	50	50
600/60/3	33.7	40	40

- ELECTRICAL CONNECTIONS**  
CONNECTION INFORMATION  
(AFF = ABOVE FINISHED FLOOR)
- E1 ELECTRIC CONNECTION: SINGLE POINT, ELEC, GAS, & STEAM, 1-1/4" CONDUIT HOLE OR 2" CONDUIT, 63-3/4" AFF
  - E2 ELECTRIC CONNECTION: BOOSTER. 30KW, 1-1/4" CONDUIT HOLE OR 2" CONDUIT HOLE, 63-3/4" AFF
  - E3 ELECTRIC CONNECTION: DETERGENT, SANITIZER (LOW TEMP ONLY) AND RINSE FEEDERS. 1/2" CONDUIT. 64-1/4" AFF
- PLUMBING CONNECTIONS**
- P1 DRAIN: 2" FPT, 7-3/8" AFF TWO POSSIBLE CONNECTIONS; MAY BE DRAINED TO EITHER SIDE OF VALVE, PLUG OPPOSITE SIDE.
  - P3 RINSE FEEDER: REMOVE 1/8" NPT PIPE PLUG TO ACCESS TAPPED HOLE. 1/8" NPT 59-9/16" AFF.
  - P4 DETERGENT PROBE SENSOR: REMOVE CAP AND STUD ASSEMBLY TO ACCESS 7/8" DIA HOLE (WASH TANK ONLY). 14-5/8" AFF.
  - P5 INDIRECT DRAIN—FLOOR SINK: BY OTHERS, 0" AFF. WHEN REQUIRED, INSTALL FLOOR SINK OUTSIDE THE PERIMETER OF THE DISHWASHER.
- STEAM HEAT ONLY**
- P8 STEAM COILS: 10 TO 50 PSI FLOWING, 3/4" FPT, 11-1/8" AFF.
  - P9 CONDENSATE RETURN: A 10 PSI MINIMUM DIFFERENTIAL PRESSURE ACROSS THE STEAM TRAP MUST BE MAINTAINED. 3/4" FPT. 11-1/8" AFF ONE CONNECTION. (ONE BUCKET TYPE TRAP FURNISHED).
- DRAIN WATER TEMPERING (INCLUDED)**
- P12 COLD WATER CONNECTION: 1/2" FPT, COLD TEMP 80°F MAX 7-3/8" AFF.
- DRAIN WATER ENERGY RECOVERY**
- P13 HOT WATER CONNECTION: 1/2" FPT, 11-3/16" AFF. HIGH TEMP, W/30K BOOSTER 110°F MIN.
  - P14 COLD WATER CONNECTION: 1/2" FPT, 11-3/16" AFF. COLD TEMP, 55°F MIN.

- PLUMBING NOTES:**
- WATER HAMMER ARRESTOR (MEETING ASSE-1010 STANDARD OR EQUIVALENT) TO BE SUPPLIED (BY OTHERS) IN COMMON WATER SUPPLY LINE AT SERVICE CONNECTION.
- RECOMMENDED WATER HARDNESS TO BE 3 GRAINS OR LESS FOR BEST RESULTS.
- FOR NON-BOOSTER MACHINE (P6 CONN):
- RECOMMENDED BUILDING FLOWING WATER PRESSURE TO THE DISHWASHER IS 20 PSI, (15 PSI MIN - 25 PSI MAX). IF PRESSURES HIGHER THAN 25 PSI ARE PRESENT, A PRESSURE REGULATING VALVE WITH INTERNAL THERMAL EXPANSION BY-PASS, MUST BE SUPPLIED (BY OTHERS) IN THE WATER LINE TO THE DISHWASHER.
- FOR CONVENIENCE WHEN CLEANING, WATER TAP SHOULD BE INSTALLED NEAR MACHINE WITH HEAVY DUTY HOSE AND SQUEEZE VALVE.
- WHEN USED, CHEMICAL SANITIZING FEEDER MUST BE CERTIFIED TO NSF STANDARD 29.

- MISCELLANEOUS NOTES:**
- OPTIONAL VENT HOODS OR EXTENDED HOODS EXHAUST REQUIREMENTS: 200 CFM ENTRANCE END  
400 CFM EXIT END.
- ALL DIMENSIONS TAKEN FROM FLOOR LINE MAY BE INCREASED APPROXIMATELY 3/4" OR DECREASED 1/2".
- NET WEIGHT OF MACHINE: 770 LBS (STD HEIGHT), DOMESTIC SHIPPING WEIGHT: 876 LBS (STD HEIGHT).
- CLeN LATENT AND SENSIBLE HEAT DISSIPATION INFORMATION ON OF-040459.

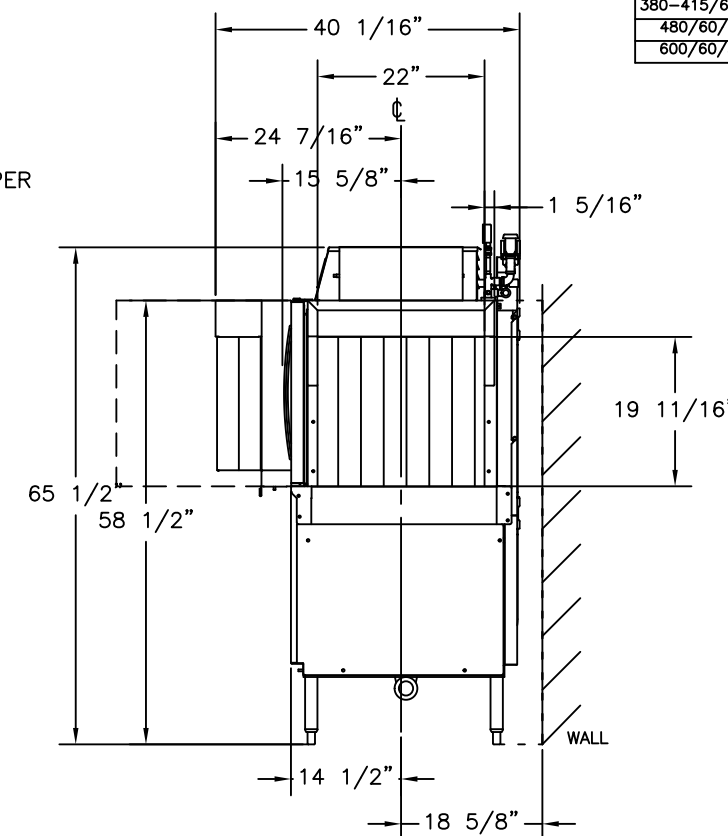
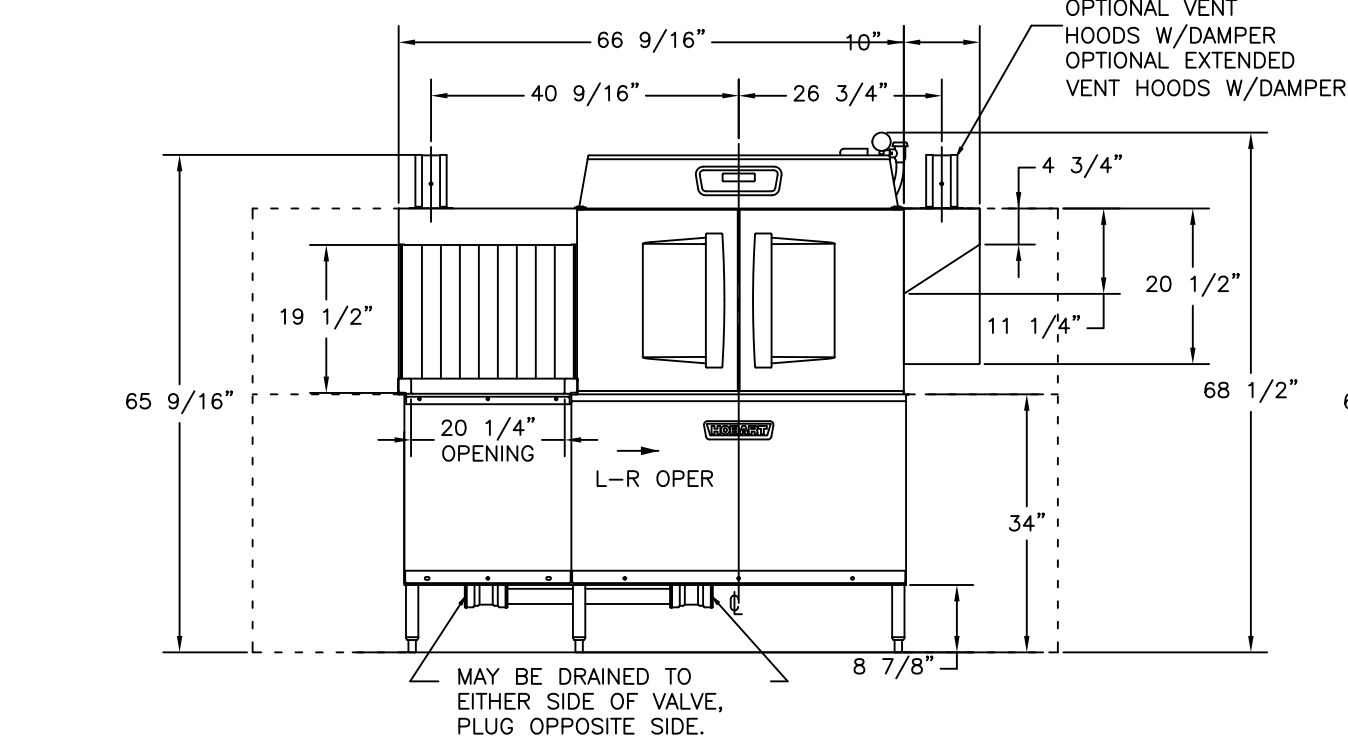

**NOTE:**

THIS DRAWING IS SUPPLIED AS A REFERENCE FOR CONNECTION INFORMATION ONLY. IT WILL NOT BE UTILIZED FOR MANUFACTURING OF UNIT.

CUSTOMER SERVICE, IN TROY, OHIO, MUST BE NOTIFIED OF ANY CHANGES.



ELECTRICAL AND GROUNDING CONNECTIONS MUST COMPLY WITH THE APPLICABLE PORTIONS OF THE NATIONAL ELECTRICAL CODE AND/OR OTHER LOCAL ELECTRICAL CODES.

PLUMBING CONNECTIONS MUST COMPLY WITH APPLICABLE SANITARY, SAFETY, AND PLUMBING CODES.

H.O.#  
PROJECT#  
QUOTE#

REV	DESCRIPTION	DATE	INIT.
NAME:	SALES DRAWING		
MODEL:	CLCS66eN-EGR-STM-L-R, STEAM HEAT		
DIRECTION:	L-R		
DRAWN BY:	DATE:	1/19/17	
HOBART		SIZE	DRAWING NO.
		Y	
		SHEET	REV.
		1	1
		OF	1